



Kairos





Massima cura per la qualità del mobile finito: ogni singolo pannello durante la lavorazione, appoggia sempre sulla parte corrispondente al lato interno del mobile, assicurano l'assenza di imperfezioni sulla parte esterna.

Excellent quality of final product: each panel is machined laying on furniture's inner side, preventing the outer side from any scratch.

Qualité excellente du meuble fini: durant l'usinage, chaque panneau est en appui sur la partie interne du meuble garantissant ainsi l'absence d'imperfection sur la partie externe.

Maxima calidad del mueble: durante el proceso, cada panel siempre apoya en la parte correspondiente al lado interno del mueble, asegurando la ausencia de imperfecciones en la parte externa.

Unità di lavorazione completa di armadi in soli 3.4 m²

Complete Processing Unit of cabinets in only 3.4 m²

Unité de traitement complète des armoires en seulement 3.4 m²

Unidad de procesamiento completa de armarios en solos 3.4 m²

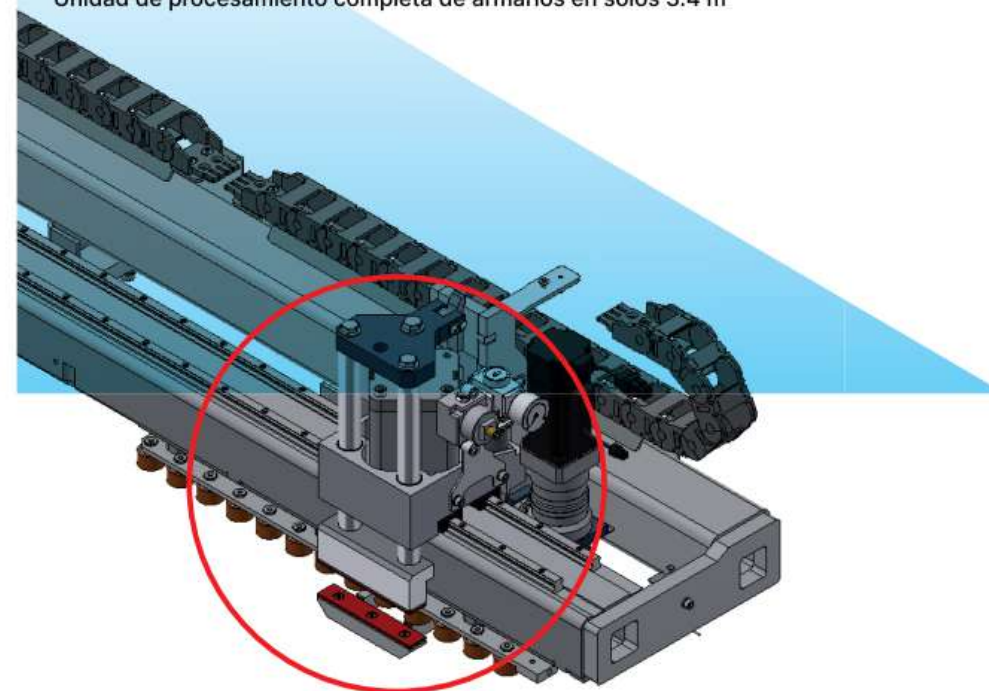

Robusta pinza per la traslazione del pannello con scorrimento su guida lineare e movimentazione con vite a ricircolo di sfere ad alta precisione e rigidezza.

Motorizzazione Brushless

Robust clamping device for panel translation running on linear guides with preloaded ball bearings and moving by means of ballscrew with high precision and stiffness.

Brushless Motor

Robuste pince pour le déplacement du panneau sur les guides linéaires et mouvement par vis à recirculation de sphères précis et rigides.

Motorisation Brushless

Pinza robusta para la traslación del panel, sobre guías lineales y movimentación con tornillo a recirculo de esferas de alta precisión y rigidez.

Motorización Brushless

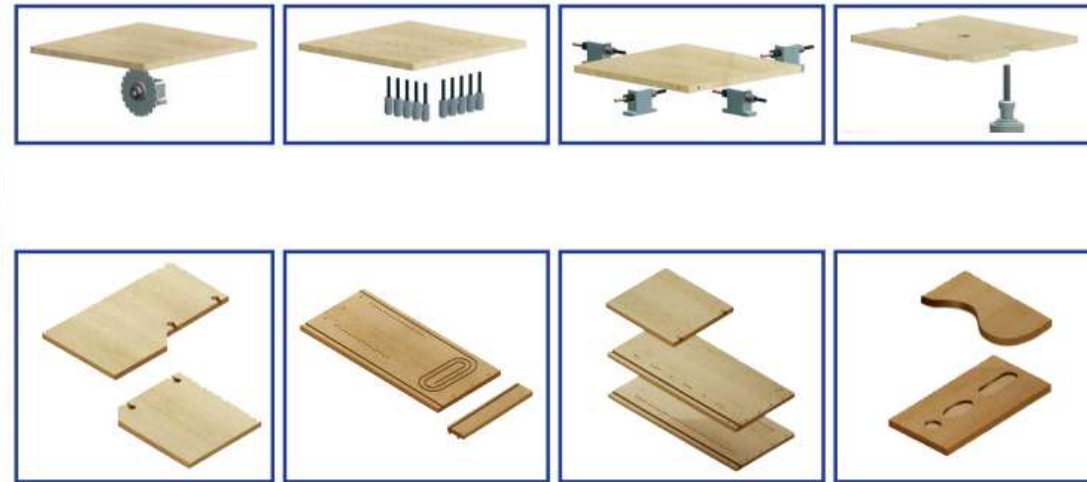
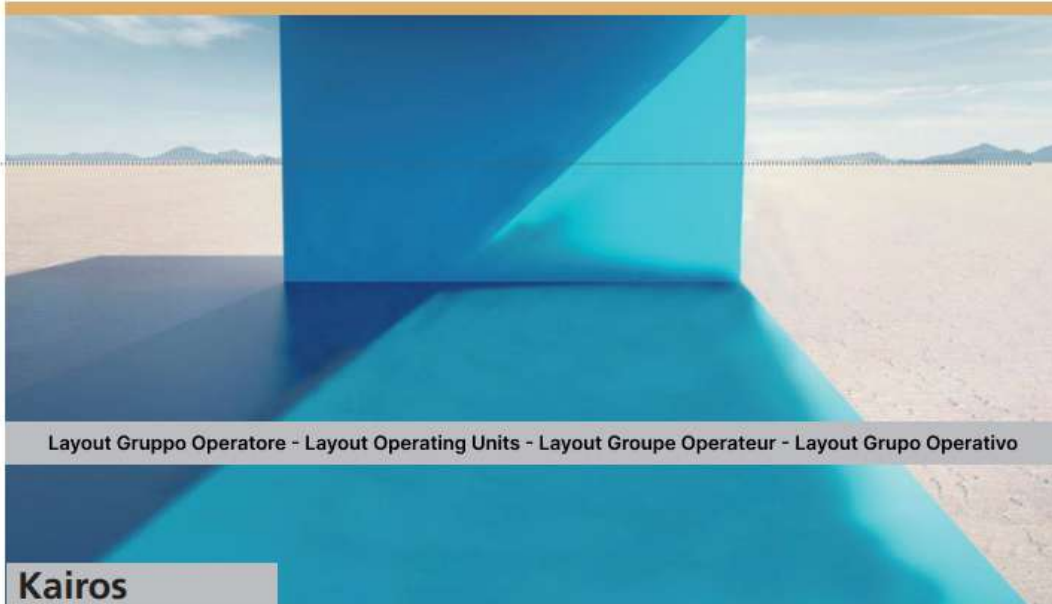

N. 9 Mandrini Indipendenti Verticali
 N. (2+2) Mandrini Orizzontali Asse X
 N. (2+2) Mandrini Orizzontali Asse Y

N. 9 Independent Vertical Spindles
 N. (2+2) X Axis Horizontal Spindles
 N. (2+2) Y Axis Horizontal Spindles

N. Broches Verticales Indépendantes
 N. (2+2) Broches Horizontales Axes X
 N. (2+2) Broches Horizontales Axes Y

N. 9 Mandriles Indipendientes Verticales
 N. (2+2) Mandriles Horizontales Eje X
 N. (2+2) Mandriles Horizontales Eje Y

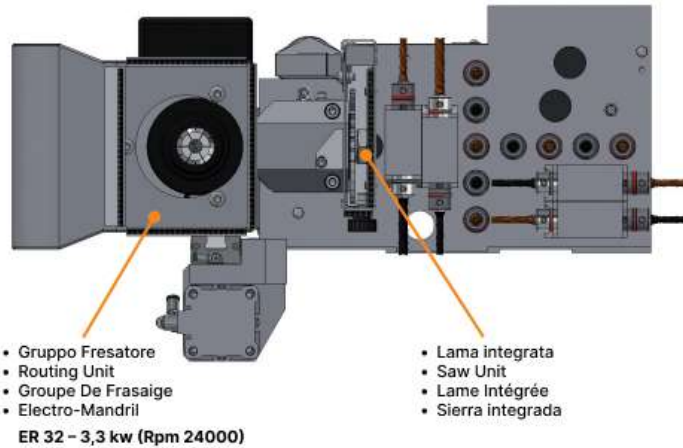

Testa di foratura con mandrini verticali, orizzontali e lama integrata. La movimentazione su guide e viti a ricircolo di sfere conferisce al gruppo elevata precisione e rigidità. **Aspirazione Trucioli Centralizzata**

Boring head with vertical and horizontal spindles plus grooving saw unit. Displacement on guides and preloaded lead screws guarantee precision and firm movement. **Centralized Chips Suction Outlet**

Tête de parçage à mèches verticales, horizontale et lame intégrée. Le déplacement sur les guide et les vis à recirculation de sphères garantissent précision et rigidité. **Aspiration Copeaux Centralisée**

Grupo de taladros, completo de : Mandriles Verticales, Horizontales y sierra integrada. El movimiento sobre guías y tornillos a recirculación de esferas confiere al grupo elevada precisión y rigidez. **Aspiración centralizada**



U DATI TECNICI (standard)

Numero di mandrini indipendenti verticali:	9
Numero di mandrini orizzontali sull'asse X:	(2+2)
Numero di mandrini orizzontali sull'asse Y:	(2+2)
N° 1 lama:	(ø 100 mm)
N° 1 Pantografo:	ER 3,2 - 3,3 KW (Rpm 24000)
Max. Spessore del pannello:	50 mm
Controllo:	Parametrico completo
Peso massimo del pannello:	Kg 40
Dimensioni max del pannello:	X Ø, Y 920, Z 50 mm
Dimensioni del pannello min:	X 270, Y 185 (70 opt.), Z 3 mm
Numero di assi controllati:	3
Velocità di alimentazione del pannello:	25 m / min
Velocità rotazione dei mandrini:	3600 giri / min
Velocità rotazione della lama:	7000 giri / min
Pressione d'aria:	7 bar
Diametro aspirazione:	2 x ø 120 mm + 1 x ø 50 mm
Dati aspirazione :	(2700 mc / ora) - (30 m / s)
Max prof. di foratura in orizz. su assi X e Y:	X 43mm - Y 30 mm
Max profondità di foratura in verticale:	43 mm
Max diametro orizzontale degli utensili:	15 mm
Max diametro verticale degli utensili:	35 mm
Potenza motore testa a forare:	1,7 kw
Potenza totale:	7 Kw
Consumo aria:	750 nlt / min.
Dimensioni:	2300x1650x1890 mm
Peso:	Kg 850
Norme CE	

TECHNICAL DATA (standard)

Number of vertical independent spindles:	9
Number of horizontal spindles on axis X :	(2+2)
Number of horizontal spindle on axis Y:	(2+2)
N° 1 saw blade unit:	(ø 100 mm)
N° 1 Router head:	ER 3,2 - 3,3 KW (Rpm 24000)
Max. thickness of the panel:	50 mm
Control:	Full Parametric
Max weight of the panel:	Kg 40
Max panel size:	X Ø, Y 920, Z 50 mm
min panel size:	X 270, Y 185 (70 opt.), Z 3 mm
Number of controlled axes:	3
Panel feeding speed:	25 m/min
Spindles speed rotation:	3600 rpm
Saw blade speed rotation:	7000 rpm
Air pressure:	7 bar
Diameter of the dust extraction:	2 x ø 120 mm + 1 x ø 50 mm
Suction system data:	(2700 mc / hour) - (30 m/s)
Max drilling depth in horiz. on X and Y axis:	X 43mm - Y 30 mm
Max drilling depth in vertical:	43 mm
Max horizontal diameter of the tools:	15 mm
Max vertical diameter of the tools:	35 mm
Motor power drilling head:	1,7 kw
Total power:	7 Kw
Air consumption:	750 nlt / min.
Size:	2300x1650x1890 mm
Weight:	Kg 850
CE Standards	

U DONNEES TECHNIQUES (standard)

Numéro mandrins indépendant verticaux:	9
Numéro mandrins horizontaux sur l'axe X:	(2+2)
Numéro mandrins horizontaux sur l'axe Y:	(2+2)
N°1 lame pour exécution de la rèneure	(ø 100 mm)
N°1 tete defonçage:	ER 3,2 - 3,3 KW (Rpm 24000)
Max. épaisseur du panneau:	50 mm
Commande numérique:	Full Parametric
Max poids di panneau:	kg 40
Dimensions Max du panneau:	X Ø, Y 920, Z 50 mm
Dimensions min du panneau:	X 270, Y 185 (70 opt.), Z 3 mm
Numéro axes contrôlés:	3
Vitesse d'avancement du panneau:	25m/min
Vitesse de rotation des mandrins:	3600 rpm
Vitesse de rotation lame:	7000 rpm
Pression d'exercice:	7 bar
Diamètre hotte d'aspiration:	2 x ø 120 mm + 1 x ø 50 mm
Données aspiration:	(2700 mc / heure) - (30 m/s)
Max profondeur de perçage horizontal axes X et Y:	X 43mm - Y 30 mm
Max profondeur de perçage vertical:	43 mm
Max diamètre de la mèche horizontal:	15 mm
Max diamètre de la mèche vertical:	35 mm
Moteur tete de perçage:	1,7 kw
Puissance totale:	7 kw
Air consumption:	750 nlt / min.
Dimension:	2300x1650x1890 mm
Poids:	kg 850
Normes CE	



STANDARD

- Dotato di laser per corretta lettura lunghezza pannello ed un perfetto assemblaggio del mobile.
- Equipped with laser for correct panel length reading and perfect cabinet assembly.
- Équipé d'un laser pour une lecture correcte de la longueur du panneau et un assemblage parfait de l'armoire.
- Equipado con laser para lectura exacta largo panel y una perfecta construcción del mueble.

U DATOS TECNICOS (estandar)

Numero mandriles independientes verticales:	9
Numero de mandriles horizontales eje X:	(2+2)
Numero mandriles horizontales eje Y:	(2+2)
N°1 lama para ranurar parte trasera del mueble:	(ø 100 mm)
N°1 router:	ER 3,2 - 3,3 KW (Rpm 24000)
Max espesor panel:	50 mm
Control:	Full Parametric
Max peso panel :	Kg 40
Dimensiones Max panel (mirar layout):	X Ø, Y 920, Z 50 mm
Dimension Min. panel:	X 270, Y 185 (70 opt.), Z 3 mm
Numero ejes controlados:	3
Avanze panel :	25 m/min
Rotacion mandriles :	3600 rpm
Revoluciones Sierra:	7000 rpm
Presion de trabajo:	7 bar
Diametro boca de aspiracion:	2 x ø 120 mm + 1 x ø 50 mm
Aspiracion:	(2700 mc / hour) - (30 m/s)
Max profundidad taladros Horiz. en X y Y:	X 43mm - Y 30 mm
Max profundidad taladros Vert.:	43 mm
Diametro Max broca Horizontal:	15 mm
Diametro Max broca Vertical:	35 mm
Motor:	1,7 kw
Potencia total:	7 Kw
Consumo de aire:	750 nlt / min.
Dimensiones:	2300x1650x1890 mm
Peso:	Kg 850
Norme CE	

WORKING MEASURES

